

Classification:

Reference:

COPYRIGHT© NISSAN NORTH AMERICA, INC.

Date:

BF90-008

ITB90-026

May 31, 1990

## DOOR KEY LOCK CYLINDER REMOVAL

**APPLIED VEHICLE(S):**

1990 Q45

### SERVICE INFORMATION

When removing or replacing the Q45 door handle or Vehicle Security System [V.S.S.] tamper switch, the door key lock cylinder must be removed. The cylinder is secured to the door handle by a wire spring retainer, P/N XA1HA-06501XX, (Figure 1).

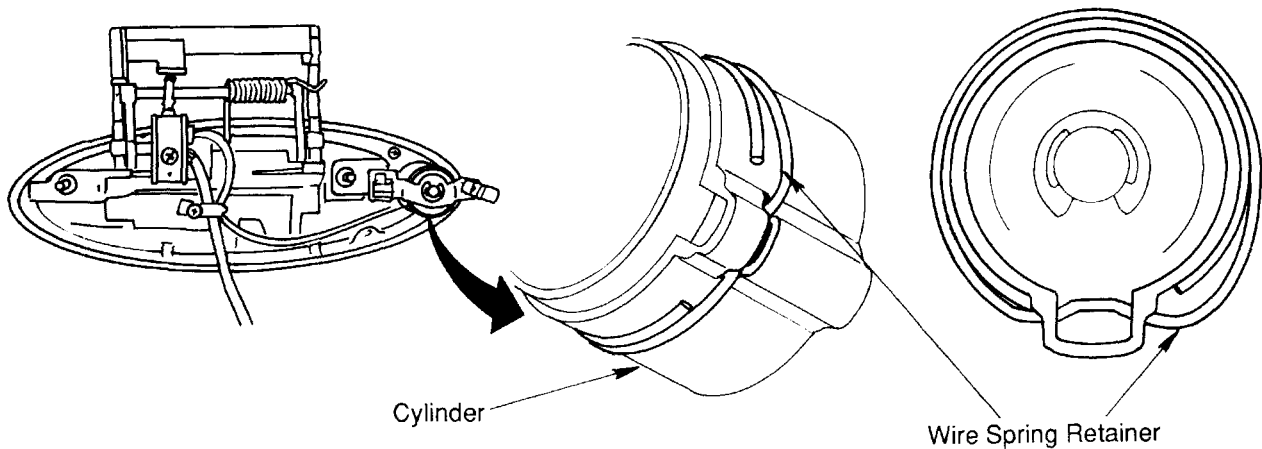

Figure 1

### SERVICE PROCEDURE

1. Remove the door interior trim panel and door handle/lock cylinder attaching linkages.
2. Loosen or remove the 2 door handle retaining nuts from the inside.

3. While pulling the handle assembly outward, use a small flathead screwdriver and, from the outside, lift the spring retainer away from the lock cylinder, allowing it to release from the door handle (Figure 2).

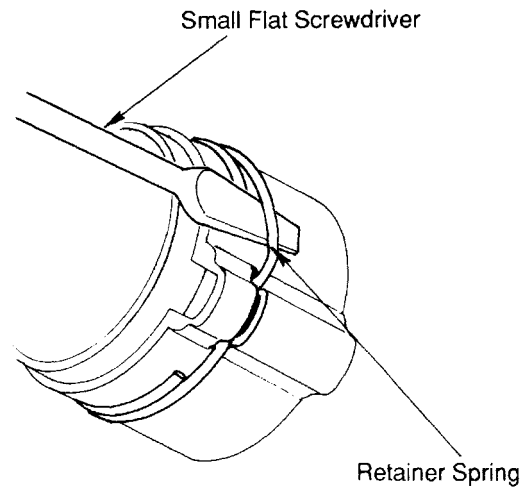

Figure 2

4. Reassemble the lock cylinder into the door handle assembly. The lock cylinder should snap easily back into the door handle after resetting the retainer spring into the latching position.